

Avery Dennison[®]

TrafficJet[™] Xpress LED Glass Replacement

Instructional Bulletin : # 9.82
Revision : # 01
Last Updated : September 2023

Replace with new LED glass if the ink hardens and the existing LED glass becomes dirty.

1. On the LOCAL mode screen, select [MENU] > [Maintenance], then press the [ENTER] key. The Maintenance menu is displayed.
2. Select [Station] > [Carriage Out] > [Head Maint.], then press the [ENTER] key. The carriage moves to the maintenance space.
3. Open the maintenance covers.

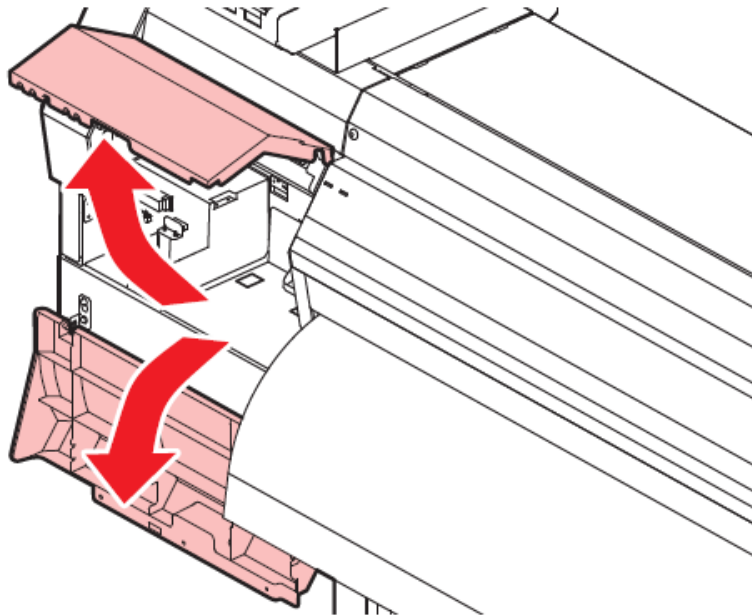

4. Remove the LED glass. Unclip the tabs and slide in the direction indicated by the arrow to remove. Be careful not to apply too much force when unclipping the tabs. Disregarding this precaution may cause the tabs to break.

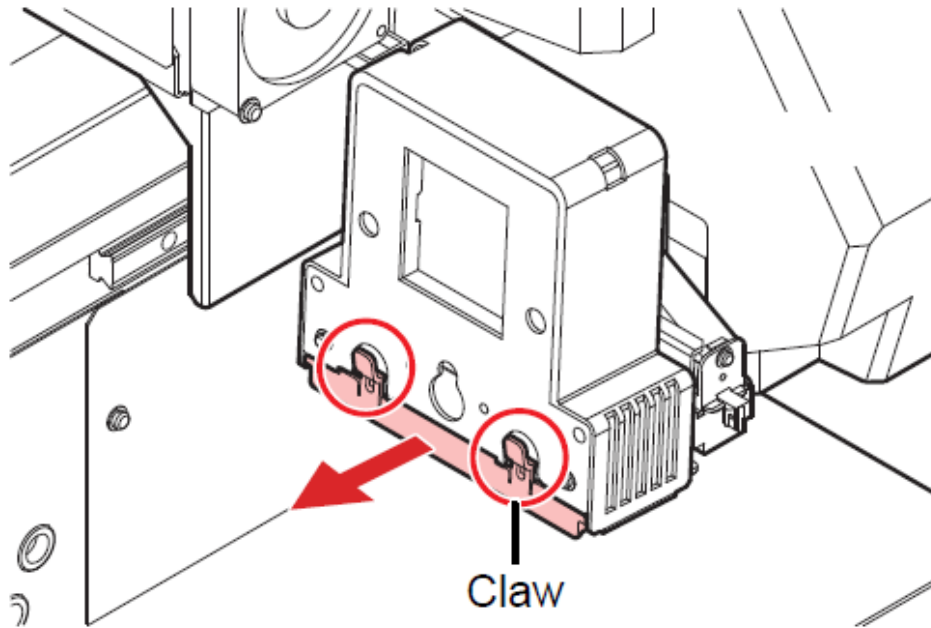

5. Mount a new LED glass. Insert until it clicks into place. Confirm that the tabs are engaged.

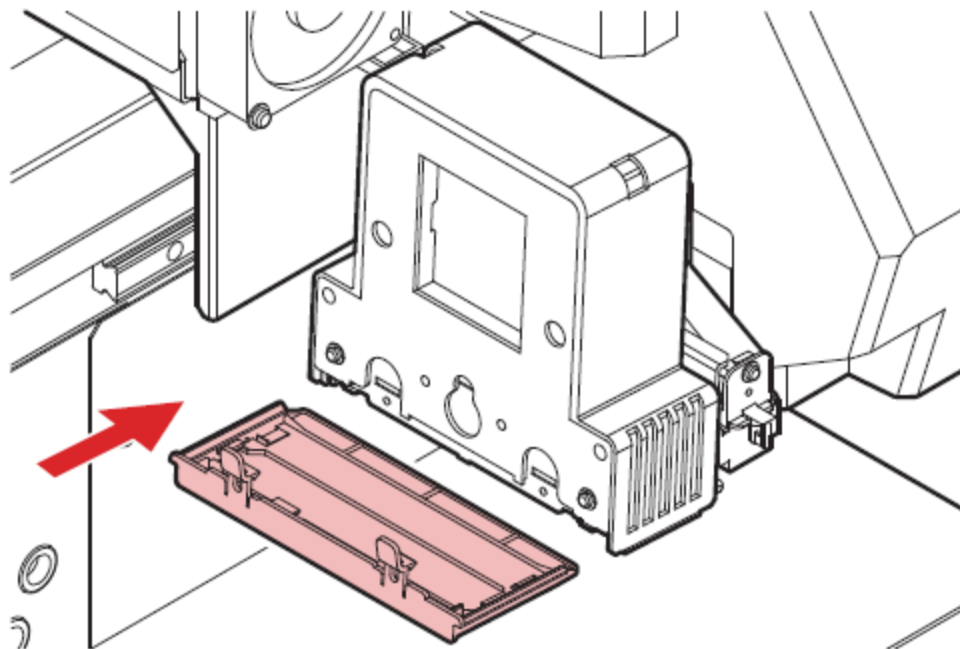

6. Once replacement is complete, close the cover, then press the [ENTER] key.

The above Avery Dennison literature provides information to the user for proper application, storage, and other requirements. Please refer to Product Data Bulletins or your local Avery Dennison Representative for warranty information. Find the latest information on the Avery Dennison website, www.reflectives.averydennison.com. We encourage you to check our website periodically for updates.

All statements, technical information, and recommendations about Avery Dennison products are based upon tests and information believed to be reliable but do not constitute a guarantee or warranty of any kind. All Avery Dennison products are sold with the understanding that Purchaser has independently determined the suitability of such products for its intended and other purposes.

For technical questions, please contact:

North America: reflective.tech.na@averydennison.com

Europe, Middle East & Africa: reflective.tech.emea@eu.averydennison.com

Asia Pacific: reflective.tech.ap@ap.averydennison.com

South America: reflective.tech.sa@averydennison.com