

Avery Dennison®

TrafficJet™ Xpress Print Head Nozzle Washing

Instructional Bulletin : # 9.78

Revision : # 01

Last Updated : August 2023



1. If print defects (e.g., nozzle clogging, deflection) remain unresolved even after head cleaning, apply nozzle washing to the print head.
2. In LOCAL mode, select [MENU] > [Maintenance], then press the [ENTER] key. The Maintenance menu is displayed.
3. Select [Station] > [Nozzle Wash], then press the [ENTER] key. The carriage moves over the platen.

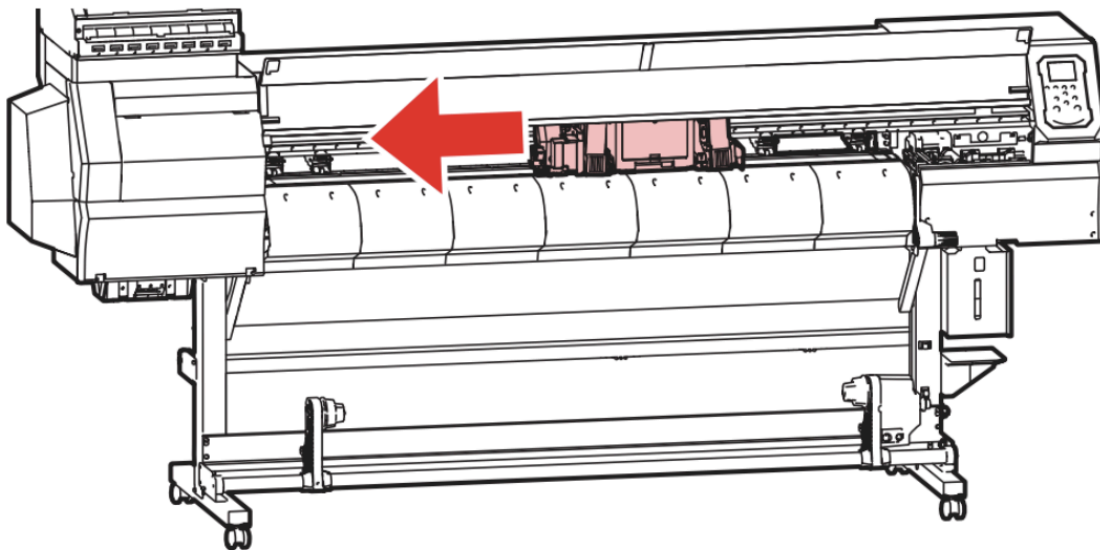

4. Open the front cover.
5. Clean the wiper and bracket. [TrafficJet™ - Xpress CLEAR Maintenance IB# 9.77](#)
6. Press the [ENTER] key once cleaning is complete. “Cap Cleaning Completed(Next)[ENT]” appears on the display.
7. Clean the cap rubber. [TrafficJet™ - Xpress CLEAR Maintenance IB# 9.77](#)
8. Press the [ENTER] key once cleaning is complete. “Fill the Liquid. Exit Next [ENT]” appears on the display.
9. Fill the cap with Flush. Use a syringe to draw up some Flush and fill until it almost overflows from the cap.

Instructional Bulletin IB# 9.78

TrafficJet™ Xpress Print Head Nozzle Washing

reflectives.averydennison.com

Classification: Avery Dennison - Confidential

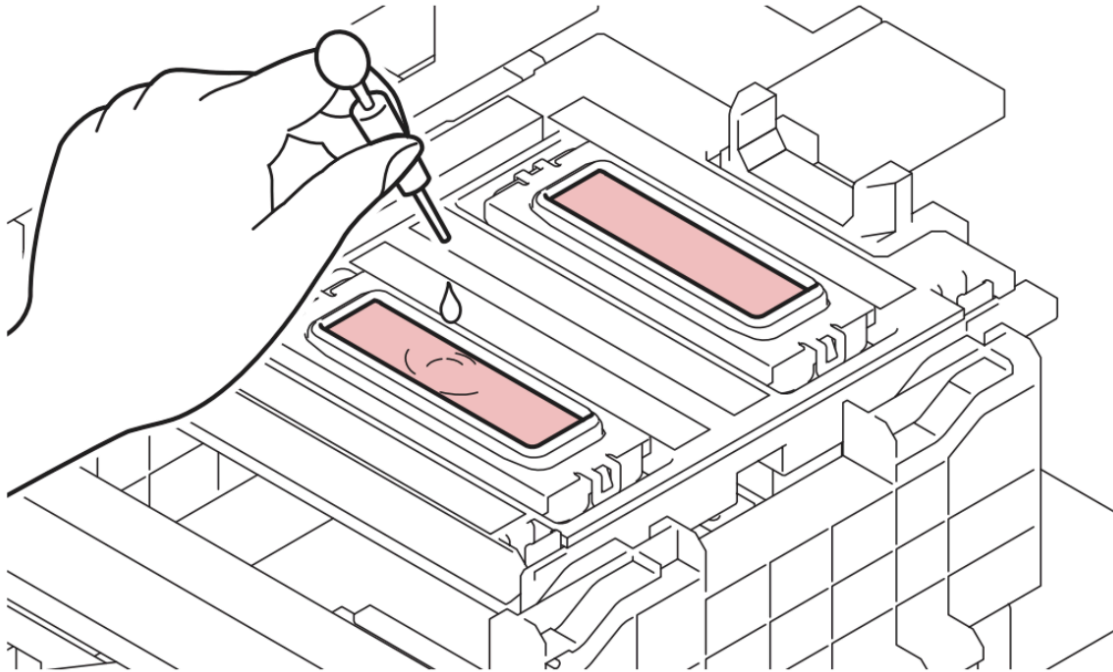

10. Press the [ENTER] key. The print nozzles are washed. "Please wait" appears on the display. Nozzle washing takes approximately one minute. Cleaning is performed automatically once print nozzle washing has ended.
11. Close the front cover, then press the [ENTER] key.

If there are still nozzles missing after this procedure, please contact your local Technical Services Representative.

The above Avery Dennison literature provides information to the user for proper application, storage, and other requirements. Please refer to Product Data Bulletins or your local Avery Dennison Representative for warranty information. Find the latest information on the Avery Dennison website, www.reflectives.averydennison.com. We encourage you to check our website periodically for updates.

All statements, technical information, and recommendations about Avery Dennison products are based upon tests and information believed to be reliable but do not constitute a guarantee or warranty of any kind. All Avery Dennison products are sold with the understanding that Purchaser has independently determined the suitability of such products for its intended and other purposes.

For technical questions, please contact:

North America: reflective.tech.na@averydennison.com
Europe, Middle East & Africa: reflective.tech.emea@eu.averydennison.com
Asia Pacific: reflective.tech.ap@ap.averydennison.com
South America: reflective.tech.sa@averydennison.com